

## PRE INSTALLATION CHECKLIST

**IMPORTANT NOTICE:** If you have purchased a STI 6400-TX model, before installation you will need to 'learn' the transmitter to the WCP-RF Merlin Pro. Please refer to the WCP-RF Merlin Pro installation and programming guide, page 13 'Adding a Wireless Device'. Once 'learned', follow steps 1-7 opposite.

### DO YOU WANT HIGH OR LOW SOUNDER OUTPUT?

The Exit Stopper is factory set for HIGH sounder output (97 dB). To change the unit to a LOW output (95 dB), locate JP2 and move to the OFF position.

### DO YOU WANT THE EXIT STOPPER TO ALARM IMMEDIATELY?

The Exit Stopper is factory set to arm immediately after the key is turned to the ON position. You can change this to a 15 second arming delay. This feature allows an authorised key holder to turn the unit on and then exit through the door before the unit arms. To set a 15 second arming delay move jumper JP7 to the OFF position.

### DO YOU WANT THE EXIT STOPPER TO ACTIVATE IMMEDIATELY THE DOOR IS OPENED?

The Exit Stopper is factory set to activate immediately the protected door is opened. The unit can be set for a 15 second delay. This would allow an authorised key holder to open the door and turn the Exit Stopper off before it activates. To set to a 15 second activation delay move the jumper to JP5 to the ON position.

### SOUNDER OUTPUT OPTIONS

The Exit Stopper is factory set to sound for 30 seconds once activated. There are three other settings, 180 seconds, continuous and 5 beeps.

## SPECIFICATIONS

Housing	3mm 1/8" polycarbonate
Power Source	9 VDC Alkaline
Sounder Output	95 dB - low/97 dB - high
Relay Output	9 VDC, 40mA
Dimensions	136mm/5.35" h x 136mm/5.35" w x 50mm/1.97" d
Standby Current	10uA
Alarm Current	200mA

## EXIT STOPPER PART NUMBERS

PART No.	DESCRIPTION
STI 6400	Exit Stopper
STI 6402	Exit Stopper Double Door
STI 6400/RK	Remote Kit
STI 6400/RS	Remote Sounder

## ACCESSORIES

PART No.	DESCRIPTION
STI F021	Tamperproof Tool
STI C023/A	Spare Keys
STI BAT1	9 V Battery
STI L6400	Emergency Exit Warning Sign

**Safety Technology International (Europe) Ltd**  
 Unit 49G, Pipers Road, Park Farm Ind. Est., Redditch Worcs, B98 0HU, UK  
 Telephone: +44 (0) 1527 520 999 Fax: +44 (0) 1527 501 999  
 Email: info@sti-europe.com Web: www.sti-europe.com

ID6400-6400TX - Revised 04/06-001 - Printed in England

## EXIT STOPPER

A completely self-contained security system that provides a highly effective, extremely versatile and inexpensive way to help prevent unauthorised use of fire/emergency doors. The EXIT STOPPER is supplied with an installation kit and 9v alkaline battery. It also incorporates a key override facility for authorised personal.

## INSTALLATION DATA FOR THE STI6400 & STI6400-TX

1. Make sure key switch is in the OFF position.
2. Remove cover from base unit by applying pressure to the key barrel. Ensure that the tamper screw located on the bottom right hand side is removed by using the tamperproof tool provided.
3. Set switches, on circuit board, to desired alarm settings (figure 1 see over).
4. Mount base unit on or next to door using the 2 fixings provided. (See Dia. A for recommendation\*). Reed switch mounting locations can be moved to the four positions shown in Dia. A. If mounted next to door, route reed switch wire through knockout in bottom of housing as shown in figure 3.
5. Mount magnet on door frame (or door if unit is mounted next to door) using screws provided. When mounting on metal doors or door frames, use plastic spacer provided. Reed switch and magnet must be within 13mm/1/2" when door is closed. Please refer to figures 4, 5 and 6 for other mounting options.
6. To fix the cover to the base unit, hooks can be found on the inside top edge of the cover. Insert the hooks into the slots provided on the edge of the base unit (see Dia. B) and snap the cover down until it clicks into place. Using the tamperproof tool provided insert and tighten the screw to secure the cover to the base see Dia. C).
7. REMOVING THE COVER FROM THE BASE Remove the tamper screw located on the bottom right hand side with the tamperproof tool safe for future servicing and battery change.

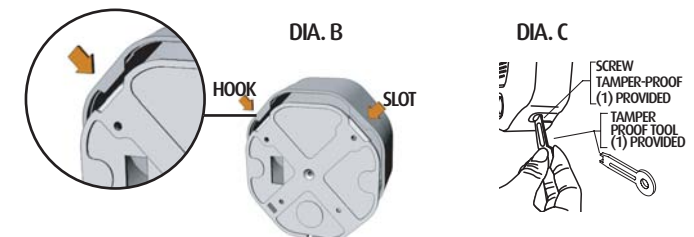
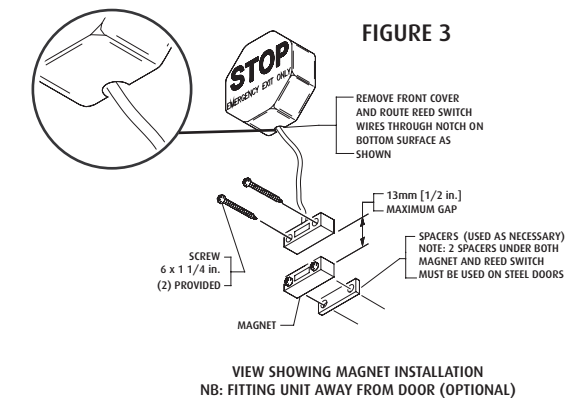
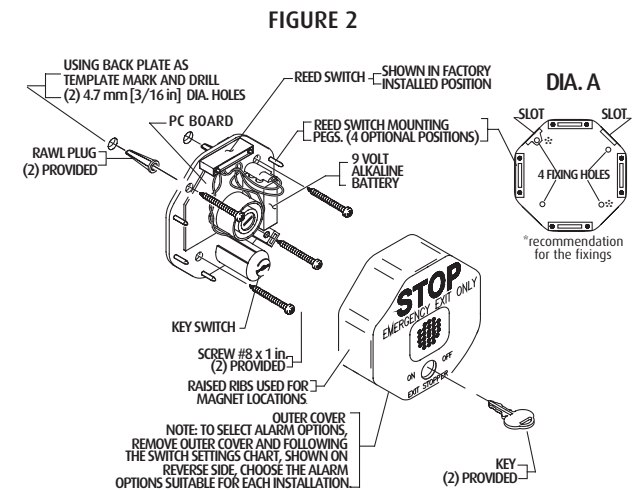

# CIRCUIT BOARD SET-UP

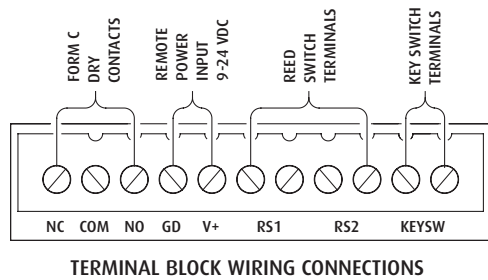
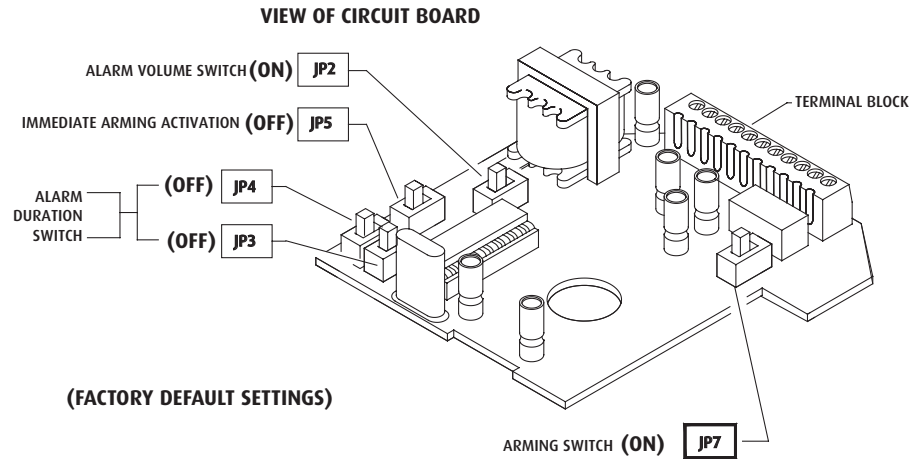

**FIGURE 1**

FEATURE	JP2	JP3	JP4	JP5	JP7
High Volume* (97 dB)	ON*				
Low Volume (95 dB)	OFF				
Immediate Arming*					ON*
15 Second Arming Delay					OFF
Immediate Arming Activation*				OFF*	
15 Second Activation Delay				ON	
30 Second Alarm Duration*		OFF*	OFF*		
180 Second Alarm Duration		OFF	ON		
Continuous Alarm Duration		ON	OFF		
Door Prop Mode (5 Beeps)		ON	ON		

\*Factory Settings

NOTE: Slide black lever to desired ON/OFF position as labelled on circuit board

# MOUNTING OPTIONS

**TYPICAL FLUSH MOUNT DOOR JAM INSTALLATION**

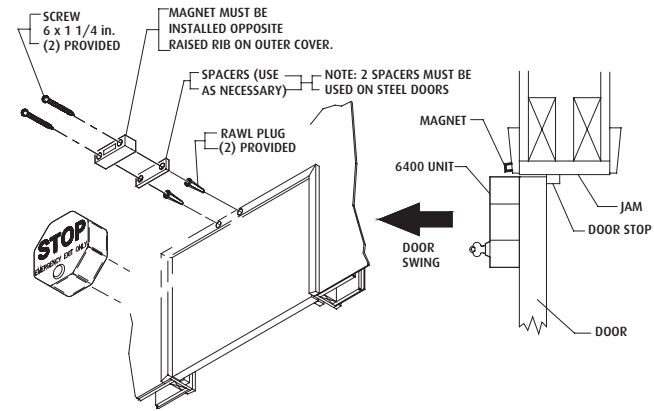

**FIGURE 4**

**TYPICAL RECESSED MOUNT DOOR JAM INSTALLATION**

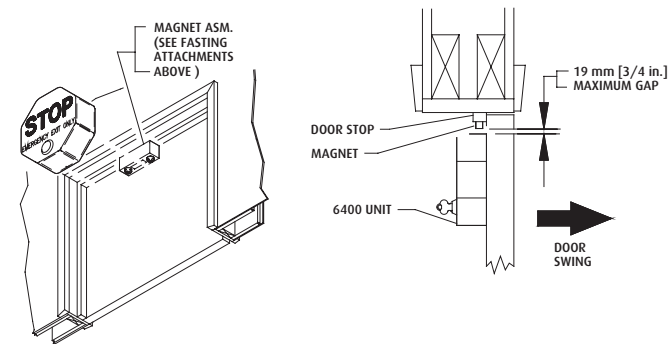

**FIGURE 5**

**TYPICAL DOUBLE DOOR INSTALLATION STI 6402**

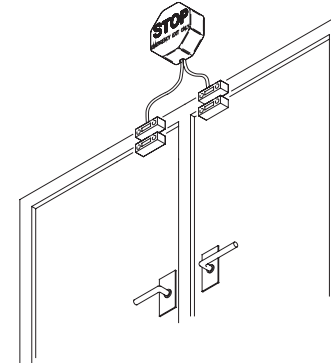

**FIGURE 6**